

N 88°09' 17" W 4932.76'  
S 88°09' 17" E 731.41'  
NORTH LINE, NE1/4, SECTION 18

TERRY L. MIDDAUGH ET AL 80 AC. (RECORDED)  
OR BK 339 - PG 2222 PN. E20-0007-0-007-00

SPENCERVILLE FARMS, LLC  
OR BK 462 - PG 565  
9.970 AC. (RECORDED)  
PN. E20-0018-0-020-01

**SPLIT PARCEL**  
**2.750 ACRES**  
PART PN. E20-0018-0-020-01

SPENCERVILLE FARMS, LLC  
OR BK 457 - PG 486 (PARCEL 2)  
10.550 AC. (RECORDED)  
PN. E20-0018-0-020-02

I HEREBY CERTIFY THIS TO BE A SURVEY MADE UNDER MY SUPERVISION  
AND THAT THE MONUMENTS ARE FOUND AND/OR SET AS INDICATED.

3-14-24  
Date

*Seth D. Schroeder*  
Seth D. Schroeder, P.S.  
Registered Surveyor No. 8784  
115 S. Fair Avenue, Suite A  
Ottawa, Ohio 45875  
419-523-5789



NW COR.,  
NW 1/4,  
SEC. 18

NE COR.,  
NE 1/4,  
SEC. 18

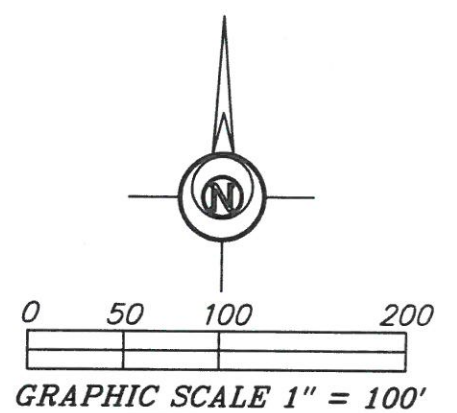

**LEGEND**

- 5/8 INCH REBAR WITH ID CAP SET
- 5/8 INCH REBAR WITH ID CAP FOUND
- 5/8 INCH REBAR FOUND
- ⊗ RAILROAD SPIKE FOUND
- MAGS MAG NAIL SET
- POB POINT OF BEGINNING

**NOTE: SURVEY BEARINGS BASED ON OHIO NORTH ZONE STATE PLANE COORDINATES OBTAINED FROM THE OHIO DOT VRS NETWORK**

**SURVEY REFERENCES:**  
Eis-B1224-D-Hic-5-12-06  
Bockrath-17-043

THIS SURVEY WAS PERFORMED WITHOUT THE BENEFIT OF A TITLE EXAMINATION. BEYOND THE DEED DOCUMENTS CITED ON THE SURVEY DRAWING THERE MAY BE RECORDED OR UNRECORDED EASEMENTS AND/OR ENCUMBRANCES BENEFITING OR ENCUMBERING THE SURVEYED PROPERTY WHICH ARE NOT SHOWN ON THIS DRAWING.

FILENAME: 24-035-BDL-2-28-24.scj DATE: 2/27/24

SURVEY PLAT FOR:  
SETH AYERS  
PART OF THE NORTHEAST QUARTER OF SECTION 18, T4N - R1E, HICKSVILLE TOWNSHIP, DEFIANCE COUNTY, OHIO

**Bockrath & Associates**  
Engineering and Surveying, LLC  
115 S. Fair Avenue, Suite A - Ottawa - Ohio  
Phone: 419.523.5789

SPENCERVILLE FARMS, LLC  
OR BK 457 - PG 486 (PARCEL 1)  
81.073 AC. (RECORDED)  
PN. E20-0018-0-020-00