

GERALD A. ZIMMERMAN TRUSTEE ETAL  
 OR VOL. 408 - PG. 1290 (PARCEL 3)  
 117.901 AC. (RECORDED)  
 PN. F12-0006-0-007-00

NE COR.,  
 SE 1/4,  
 SEC. 6  
 POC 1 & POB 2

GERALD A. ZIMMERMAN  
 TRUSTEE ETAL  
 OR VOL. 408 - PG. 1298  
 (PARCEL 7)  
 121.457 AC. (PER TAX RECORD)  
 PN. F12-0006-0-002-00

JAY H. & REBECCA K. SMITH  
 OR BK. 458 - PG. 666  
 38.150 AC. (RECORDED)  
 PN. F12-0006-0-004-04

**PARCEL 1**  
**38.295 ACRES**

ANDREW JACKMAN ETAL  
 OR BK. 426 - PG. 2686  
 68.90 AC. (RECORDED)  
 PN. F12-0006-0-002-00

**PARCEL 2**  
**40.252 ACRES**

PT. PN. F12-0006-0-004-04  
 PT. PN. F12-0006-0-004-02

MATTHEW D. GERKEN  
 OR BK. 320 - PG. 249  
 5.00 AC. (RECORDED)  
 PN. F12-0006-0-003-02

JOHN RYAN &  
 STACY LYNN YEUTTER  
 OR BK. 403 - PG. 522  
 20.100 AC. (RECORDED)  
 PN. F12-0006-0-004-03

BRENNEMAN BROTHERS  
 OR BK. 459 - PG. 60  
 74.359 AC. (PER TAX RECORD)  
 PT. PN. F12-0006-0-004-02

**PARCEL 3**  
**33.983 ACRES**

PT. PN. F12-0006-0-004-02

DENNIS L. GERKEN  
 DEED VOL. 215 - PG. 178  
 84.46 AC. (PER TAX RECORD)  
 PN. F12-0006-0-003-00

RICHARD WILLIAM HEALY III  
 MICHELLE L. HEALY  
 OR BK. 369 - PG. 1510  
 3.511 AC. (RECORDED)  
 PT. PN. F12-0006-0-004-00

PHYLLIS J. WALDRON  
 OR BK. 440 - PG. 2108  
 2.00 AC. (RECORDED)  
 PT. PN. F12-0006-0-004-01

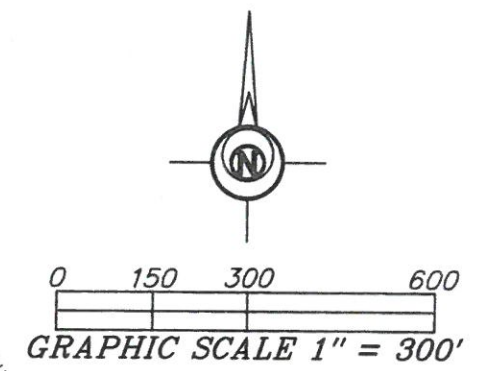

- LEGEND**
- 5/8 INCH REBAR W/ID CAP SET
  - 5/8 INCH REBAR W/ID CAP FOUND
  - 5/8 INCH REBAR FOUND
  - MAGS MAG NAIL SET
  - POB POINT OF BEGINNING
  - (R) RECORDED

**NOTE: SURVEY BEARINGS BASED ON OHIO NORTH ZONE STATE PLANE COORDINATES OBTAINED FROM THE OHIO DOT VRS NETWORK**

THIS SURVEY WAS PERFORMED WITHOUT THE BENEFIT OF A TITLE EXAMINATION. BEYOND THE DEED DOCUMENTS CITED ON THE SURVEY DRAWING THERE MAY BE RECORDED OR UNRECORDED EASEMENTS AND/OR ENCUMBRANCES BENEFITING OR ENCUMBERING THE SURVEYED PROPERTY WHICH ARE NOT SHOWN ON THIS DRAWING.

**SURVEY REFERENCES:**  
 04-06-08  
 04-06-09  
 04-06-11

I HEREBY CERTIFY THIS TO BE A SURVEY MADE UNDER MY SUPERVISION AND THAT THE MONUMENTS ARE FOUND AND/OR SET AS INDICATED.

12-14-23  
 Date

Seth D. Schroeder, P.S.  
 Registered Surveyor No. 8784.  
 115 S. Fair Avenue, Suite A  
 Ottawa, Ohio 45875  
 419-523-5789

**SURVEY PLAT FOR:** ANDY ZIMMERMAN  
 PART OF THE SE 1/4 OF SECTION 6, T3N - R5E, HIGHLAND TOWNSHIP, DEFIANCE COUNTY, OHIO

**Bockrath & Associates**  
 Engineering and Surveying, LLC  
 115 S. Fair Avenue, Suite A - Ottawa - Ohio  
 Phone: 419.523.5789

REVISED: 23-346-BDL-12-8-23.scj DATE: 11/15/23  
 FILENAME: 23-193\_BEAR\_sds\_6-19-23.scj DATE: 6/19/23

~WATSON ROAD~ N 88°52'23" W 2655.55'

04-06-12